

ROTOR FLUX VECTOR CONTROL TRACKING FOR SENSORLESS INDUCTION MOTOR

Fathima Farook¹, Reeba Sara Koshy²

Abstract—In this paper, a novel method to estimate the rotor flux position of an induction motor by injecting high frequency signal at very low speed including zero. A high frequency model based on fluctuating signal flux orientation is proposed, and the difference of the high frequency impedance of an induction motor between d and q- axes can be measured. A high frequency model of induction motor, which is oriented with high frequency signal space vector. So the rotor flux angle can be tracked by tuning the space vector of high frequency signal. The control scheme of rotor flux tracking for sensor-less flux orientation is proposed and verified by the experimental results. The experimental results show that this method is very simple to control, and it is robust against the voltage disturbances and saturation state and load change.

Keywords—Flux tracking, speed sensor-less control, high frequency signal injection

I. INTRODUCTION

A key requirement for sensorless control of an induction motor is the ability to determine the position of the flux in the machine without measuring the speed or position of the rotor. Methods for sensorless control focused on exploitation of saturation effects in an induction motor have been the subject of research in the recent years. These methods can be divided into two groups, depending on whether they use the fundamental excitation of the machine or a separate high frequency excitation. The methods based on fundamental excitation fail at low and zero speed, but methods with high frequency excitation do not have such a problem. Methods from the second group can be further divided with regard to the measured signal. This signal can be either the neutral terminal voltage which is less convenient because of the need for additional sensor, or phase currents where current sensors already exist, so there is no need for additional hardware. Moreover, there are two different methods that can be used to apply a high frequency signal to the motor. One can utilize either a high frequency signal producing rotating field or a high frequency pulsating signal [1].

Induction motor drives have been thoroughly studied the past few decades and many vector control strategies have been proposed, ranging from low cost to high performance applications. In order to increase the reliability and reduce the cost of the drive, a great effort has been made to eliminate the shaft speed sensor in most high performance induction motor drive applications. Speed estimation is an issue of particular interest with induction motor drives where the mechanical speed of the rotor is generally different from the speed of the revolving magnetic field. The advantages of speed sensorless induction motor drives are reduced hardware complexity and lower cost, reduced size of the drive motor, better immunity, elimination of the sensor cable, increased reliability and less maintenance requirements[2].

In the continuous signal injection is used, and the injection of a balanced three-phase high frequency signal is generated by the inverter to track spatial saliencies due to the saturation effect at low or zero stator frequency. A kind of discrete high frequency pulse signal injection of an induction motor is proposed. The effect that the total leakage inductance varies with the rotor position can be used to extract the rotor position, and speed. A significant limitation to these methods for low and zero stator frequency is that they depend strongly on the motor structure, and they are very sensitive to load conditions. So a new scheme to estimate the rotor flux angle by injecting high frequency fluctuating signal will be a good solution of speed sensor-less control. It injects a fluctuating signal in the terminal of stator on the estimated flux axis of the motor and the difference of the impedance of the motor between flux axis and quadrature axis is measured. However in the synchronously rotating reference frame based on rotor-flux-orientation is not suitable for the analysis of high frequency fluctuating signal injection, because the high component of quadrature axis flux of injection signal will not equal zero. In addition, the main flux density and saturation state is ignored in.

This paper is focused on a method based on injection of a high frequency pulsating voltage vector that rotates in the synchronous d - q reference frame and

scans the spatial high frequency admittance image. This method allowed one to control the motor torque, but with very limited bandwidth. An injection of a high frequency current signal is also possible, but it demands very fast acting digital current control. Such a fast control becomes increasingly difficult to achieve when the ratio between the sampling frequency and the high frequency signal becomes small.

In recent years, the vector control theory has been receiving much attention because of the better steady and dynamic performance over conventional control methods in controlling motors torque and speed. In various vector control schemes, the speed sensorless vector control has been a relevant area of interest for many researchers due to its low drive cost, high reliability and easy maintenance. There are two main parameters which are required in speed sensorless vector control of induction motor, those are, the motor flux and speed estimation. These parameters are necessary for establishing the outer speed loop feedback and also in the flux and torque control algorithms. . In order to get good performance of sensorless vector control, different speed estimation methods have been proposed. Such as direct calculation method, model reference adaptive system Observers, Estimators using artificial intelligence etc .

In this paper a high frequency model based on fluctuating signal flux orientation and a new rotor flux position tracking algorithm are proposed. From this high frequency model, the difference of the high frequency impedance of the motor between flux axis and quadrature axis can be derived. And due to the effect of the saturation state, the locus of the impedance at injected high frequency signal varies as different main flux density. Furthermore, the experimental results show that this algorithm is very simple to control, and it is very robust against the voltage disturbances and saturation state and load change.

II. NEED FOR SENSORLESS CONTROL

Volts/hertz (v/f) control and vector control are the most generally used control strategies of induction motor. In general v/f control method is used in fans, conveyors, centrifugal pumps, etc. where high performance and fast response is not needed. The v/f principle adjusts a constant Volts-per-Hertz ratio of the stator voltage by feed forward control. It serves to maintain the magnetic flux in the machine at desired level. The absence of closed loop control and the restriction to low dynamic performance make v/f controlled drives very robust. Scalar control is the technique in which the control action is obtained by the

variation of only magnitude of control variables and disregards to control the coupling effect in the machine. The voltage of the machine can be controlled to control the flux and frequency, or slip can be controlled to control the torque. The control is provided by frequency and voltage reference generator with constant volt per hertz ratio. Scalar control technique is somewhat simple to implement, but the inherent coupling effect results sluggish response and the system is easily prone to instability because of higher order system effect. The particular attraction of v/f-controlled drives is their extremely simple control structure, which favors an implementation by a few highly integrated electronic components. There is no direct or indirect control of torque and flux. The status of the rotor is ignored, i.e. no speed or position signal is feedback. These cost-saving aspects are especially important for applications at low power below 5 kW. Even though, the cost advantage makes v/f control very attractive for low power applications, while their robustness favors its use at high power when a fast response is not required. Constant Volts-per-Hertz control ensures robustness at the expense of reduced dynamic performance, which is adequate for applications like pump and fan drives, and tolerable for other applications. Although simple, this arrangement results in limited speed accuracy and poor torque response. The flux and torque responses are dictated by the response of the motor to the applied frequency and voltages are not under the control of the drive[3].

III. METHOD WITH INJECTION OF HIGH FREQUENCY PULSATING VOLTAGE

The basic principle of this method is to inject a high frequency pulsating voltage signal into the motor and then rotate this pulsating signal in order to obtain a saliency image which is caused by saturation. Since the injected signal is voltage and the measured signal is current, the saliency can be represented by the admittance corresponding to the high frequency signal. In Fig. 1 the vector diagram presents the principle of this method. The entire processing is performed in the synchronous $d-q$ reference frame which rotates with the fundamental frequency. The injected high frequency voltage signal is marked and this signal is actually a pulsating signal (this is marked with arrows) and could also be represented by two vectors rotating in opposite directions. The angle of this pulsating vector which also rotates with the frequency of 50 Hz relative to the $d-q$ frame is marked as ϵ where $\epsilon = 2\pi[50t]$. The consequence

of this injected high frequency voltage signal is the high-frequency current which is pulsating in the direction of the voltage vector. There is also a smaller pulsating current component present in the perpendicular direction.

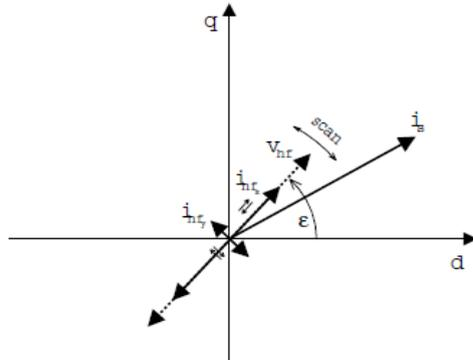

Fig. 1 Vector diagram for pulsating voltage vector injection in d - q synchronous reference frame

To track the rotor flux position a fluctuating high frequency signal is injected in terminal of the stator of an induction motor by a PWM inverter. And the injected high frequency voltage signal in the synchronously rotating reference frame can be shown as follows:

$$s_d = U_{sd}^h \sin(\omega_h) \quad (1)$$

$$s_q = U_{sq}^h \sin(\omega_h) \quad (2)$$

The superscript represents the high frequency component in steady state. In the synchronously rotating reference frame, the high frequency model of an induction motor are expressed as follows:

$$s_d = L_{sd} \dot{s}_d + L_{md} \dot{r}_d \quad (3)$$

$$s_q = L_{sq} \dot{s}_q + L_{mq} \dot{r}_q \quad (4)$$

$$r_d = L_{rd} \dot{r}_d + L_{md} \dot{s}_d \quad (5)$$

$$r_q = L_{rq} \dot{r}_q + L_{mq} \dot{s}_q \quad (6)$$

Assuming the synchronously rotating reference frame is oriented by high frequency component of rotor flux. The high frequency impedance of d -axis and q -axis are different, and they are mainly dominated by saturation of main flux and machine designs. So the locus of the impedance at the injected high frequency is an ellipse in

the synchronously rotating reference frame. This characteristic can be used to estimate the rotor flux position at low or zero stator frequency.

IV. HIGH FREQUENCY ON THE d - q REPRESENTATION OF IMPEDANCE

Speed sensorless estimation as its name implies, is the determination of speed signal from an IM drive system without using rotational sensors. It makes use the dynamic equations of the IM to estimate the rotor speed component for control purposes. Estimation is carried out using the terminal voltages and currents which are readily available using sensors. Sensor less vector control induction motor drive essentially means vector control without any speed sensor. An incremental shaft mounted speed encoder, usually an optical type is required for closed loop speed or position control in both vector control and scalar controlled drives. A speed signal is also required in indirect vector control in the whole speed range and in direct vector control for the low speed range, including the zero speed start up operation. Controlled induction motor drives without mechanical speed sensors at the motor shaft have the attractions of low cost and high reliability. Drives operating in hostile environments or in high speed drives speed sensors can't be mounted. To replace the sensor the information on the rotor speed is extracted from measured stator voltages and currents at the motor terminals[4].

Induction motors are commonly designed such that the main flux path is at least partially saturated under rated operation. The saturation of main flux path brings the asymmetry of distribution of magnetic conductivity in space. Fig. 2 (a) shows the distribution of fundamental frequency component of the flux. And the area of flowing from stator to rotor is saturated. When high frequency signal is injected at d -axis, the distribution of high frequency component of created flux is shown as Fig. 2 (b). The high frequency flux and the main flux are shared the similar paths within the part of stator core and teeth. However, due to rotor conductor skin effects, the high frequency flux does not penetrate as deeply into the rotor as does the fundamental component flux. Most of flux is concentrated on the surface of the rotor. On the other hand, when high frequency signal is injected at q -axis, the distribution of high frequency component of created flux is different from one created by d -axis high frequency injection. As the effect of saturation of main flux path, the cross-path saturation between fundamental frequency component and high frequency

the d-q axes is measured and used to tracking the rotor flux position. The Rotor Flux Tracking Controller as detailed in the Fig. 4 is used to obtain the rotor flux position. Furthermore, because the synchronous reference frame is linked to the rotor flux, the synchronous frequency is obtained by differentiate the rotor flux angle. Vector control techniques have made possible the application of induction motors for high performance applications where traditionally only DC drives were applied. The vector control scheme enables the control of the induction motor in the same way as separately excitation DC motors. As in the DC motor, torque control of induction motor is achieved by controlling the torque current component and flux current component independently. The direct vector control method depends on the generation of unit vector signals from the stator or air-gap flux signals. The air-gap signals can be measured directly or estimated from the stator voltage and current signals. The stator flux components can be directly computed from stator quantities. In these systems, rotor speed is not required for obtaining rotor field angle information. In the indirect vector control method, the rotor field angle and thus the unit vectors are indirectly obtained by summation of the rotor speed and slip frequency.

motor is used in experiments. 500Hz fluctuating voltage signal is injected into the terminals of the induction motor. In this work, the sample frequency of the control system is 8000Hz.

A. Rotor Flux Position Tracking Performance

Several steady state tests have been performed to verify the rotor flux position tracking algorithm. In this experiment the rotor is locked, and the fundamental frequency component of rotor flux is fixed, then the space vector of high frequency voltage signal is injected at -90° $+90^\circ$ degree electric angle to rotor flux vector.

Fig. 5 illustrates the high frequency components of measured current on testing axes and estimated rotor flux position, and the stator frequency is 1Hz with open loop control. Because of open loop control of rotor flux, when load is changed the magnitude of rotor flux cannot keep constant. So the saturation of the induction motor is different from former condition and the high frequency responsive currents are changed, which depend on the rotor flux saturation. However, the estimated rotor flux position is robust against the load variation.

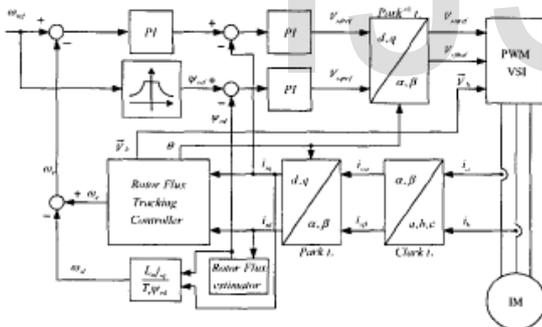
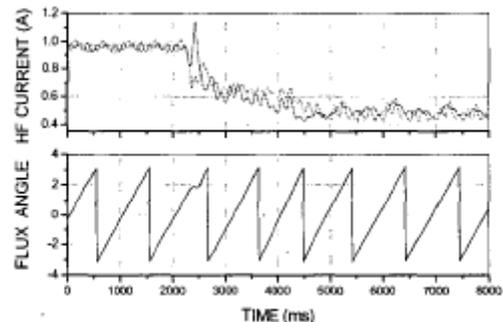

Fig. 4. Vector control of induction motor with rotor flux tracking algorithm



(a)

VI. EXPERIMENTAL RESULTS

A. Implementation Aspects

A digital system based on the TMS320C32 DSP has been used to implement the vector control of induction motor with rotor flux tracking algorithm. In addition, a PC has been used to on-line modify the various parameters and conditions used by the DSP system. And all of the variables can be monitored in windows of the PC. A 4.4kW general purpose induction

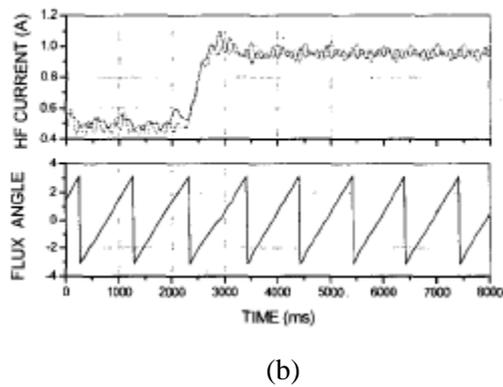

Fig.5. Rotor flux position by algorithm of flux tracking (1Hz), (a) test current and rotor flux position with step increase in the load, (b) test current and rotor flux position with step decrease in the load.

B. Closed loop Control Strategy Performance

The high frequency responsive currents keep constant. This is due to the fact that the rotor flux is under the closed loop control.

Fig6,7. The speed sensor-less Mutual inductance 0.1633H vector control of an induction motor at very low speed include zero. The rotor speed, torque, phase current, and rotor flux position are shown respectively. When step up in the load, the estimated speed ripples are larger than that in before. So a low pass filter is used in the control algorithm to avoid this effect. There are no rotor parameters are used in the novel control algorithm to estimated the rotor flux position. Furthermore, the injected high frequency voltage vector can be implemented with any desired position and rotating speed even in the fixed position. Even if the reference speed reaches zero, the accurate rotor flux position can also be estimated, and the rated torque is obtained.

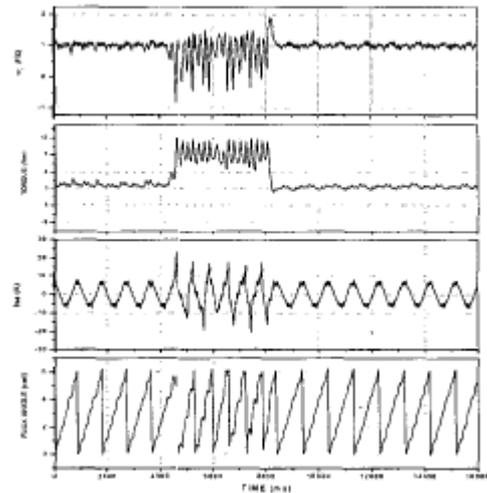

Fig. 6. Closed loop control strategy performance, step increase and decrease in the load at 1Hz rotor speed.

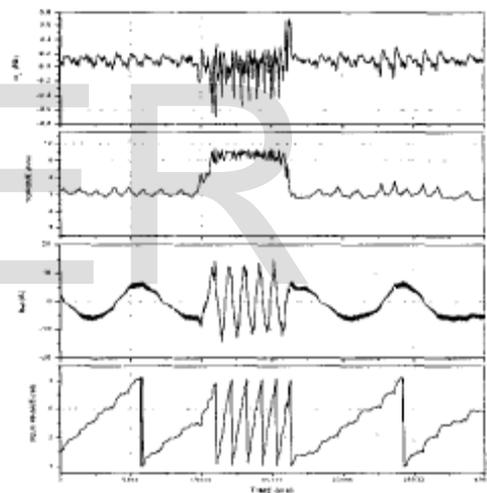

Fig. 7. Closed loop control strategy performance, step increase and decrease in the load at 0.1Hz rotor speed.

VII. CONCLUSION

Some of the strategies for sensorless induction motor drives were reviewed and the effects of including a rotor flux tracking at very low speed. A high frequency model based on fluctuating signal flux orientation is proposed, and the difference of the high frequency impedance of an induction motor between d and q- axes is discussed. Due to the effect of the saturation state, the

locus of the high frequency impedance of stator with high frequency signal injection varies as the different main flux density. The control scheme of rotor flux tracking for sensor-less flux orientation is proposed and verified. Furthermore, the experimental results show that this method is very simple to control, and it is robust against the voltage disturbances and saturation state and load change. The experimental results have also demonstrated robust and reasonably accurate continuous flux position estimation of an induction motor over very low speed included zero and loaded operating ranges. The rated torque can be obtained in very low speed ranges.

REFERENCES

- [1] Drevenšek, "A study of Sensorless Control of Induction motor at zero speed utilizing high frequency voltage injection", *International journal* 2002.
- [2] Karim Negadi, Abdellah Mansouri, And Rabeh Kourek . "Implementation Of Vector Control Of Induction motor drive without speed encoder using an adaptive Luenberger based MRAS observer", *Electronic Journal of Practices and Technologies* . 2012, p. 99-114.
- [3] Mohammad Haseeb Khan and J. Amarnath." Control of Induction motor drive without shaft encoder using model referencing adaptive system and to avoid torque jerks in transition at starting" *International Journal of Applied Engineering Research ISSN 0973-4562* Volume 4 Number 6 (2009) pp. 921–929 .
- [4] T. Raghu, J. Srinivas Rao, and S. Chandra Sekhar, "Simulation of sensorless speed control of Induction motor Using APFO technique " *International Journal of Computer and Electrical Engineering*, Vol. 4, No. 4, August 2012.
- [5] G. Pydiraju, M. Daivaasirvadam."Sensorless speed control of Induction motor using MRAS," *International Journal of Recent Technology and Engineering (IJRTE)* ISSN: 2277-3878, Volume-1, Issue-5, November 2012.